

Master`s Thesis, Term Project, Bachelor`s Thesis

Advanced Design of Composite Hydrogen Pressure Vessels.

With the new objectives for greenhouse gas reduction set by the European Union, the use of green hydrogen fuel to power vehicles or aircraft (as presented by Airbus with the ZEROe) is getting more and more interest in the industry. One of the main challenges towards the broader application of hydrogen is the improvement of onboard storage solutions. The Chair of Carbon Composites (TUM-LCC) performs research activities on the design and manufacturing of Composite Overwrapped Pressure Vessels (COPV) for hydrogen applications (automotive, truck, or aerospace). We aim to use carbon composites' full lightweight potential to reduce pressure vessels' weight, increase storage capacity, and thus enable green hydrogen mobility.

Within the scope of this work, the previously developed composite layup of a COPV will be optimized. For this purpose, the existing numerical model of the COPV for damage analysis will be extended. This includes representing the actual fiber architecture (fiber paths, layer thickness) resulting from the manufacturing process (winding) in the model. The model will be used to study the influence of relevant parameters (layup, manufacturing defects, etc.) on mechanical performance. An essential part of the thesis is the definition and selection of suitable methods to measure the actual fiber orientation and layer thickness and, later on, the data transfer into the model. Finally, the work will be validated against experimental data (burst pressure, micrographs).

This thesis will allow you to **gain experience with simulation software** and **programming** and in the **processing** and **characterization** of materials, representing a **definite advantage in your personal development for future engineering activities**.



Figure 1: Zero-emission concept aircraft [Airbus]

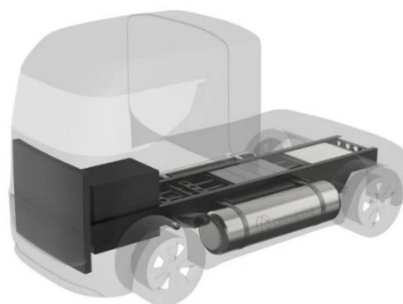

Figure 2: Hydrogen-powered truck concept [Cryomotive]

Research focus

- Extension of an existing numerical model of a COPV
- Selection of suitable methods (sensors, etc.) to measure the actual fiber orientation and layer thickness
- Manufacturing trials for measuring the actual fiber orientation and layer thickness
- Implementation of a routine to represent the actual geometry in the model
- Numerical parameter studies for the optimization of the composite layup

Requirements

- Reliable and independent way of working
- Experience with FE-Software is beneficial
- First programming experience is beneficial

Starting date: Flexible

For more details please contact:

Marco Tönjes, Room 5504.01.426, Fakultätsgebäude MW, Tel. +49 89 / 289 - 15101, marco.toenjes@tum.de